

Reducing Thermal Stress

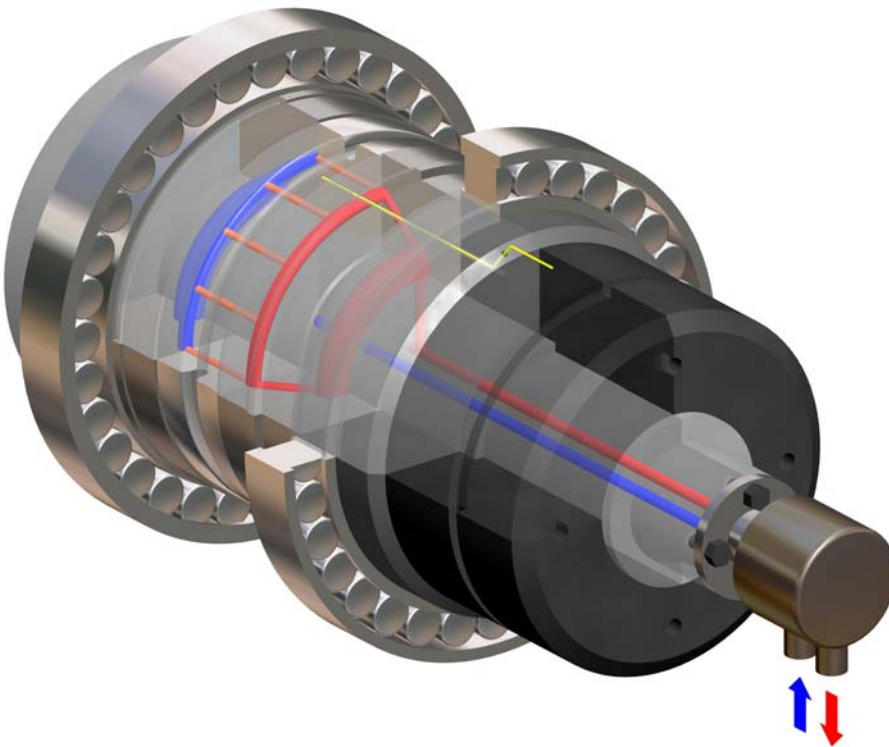

Cooling the Extrusion Wheel is a fundamental part of controlling the Conform Process.

BWE use internal cooling water to remove heat energy and a thermocouple buried just under the Wheel Groove to measure temperature.

Under ideal conditions, there is a constant thermal gradient between the Wheel Groove and the cooling channels that results in a constant rate of heat abstraction.

During start-up, when it is desirable to achieve optimum Wheel temperature as quickly as possible, there is a risk that delaying the application of cooling for too long or increasing the cooling water flow suddenly will cause excessive thermal stress which can lead to early Wheel failure.

BWE's Automatic Wheel Cooling System uses a variable-speed pump to circulate cooling water under PLC control. To ensure that the thermal gradient develops progressively, a preset "trickle" flow rate is used as soon as the machine is started. As the Wheel heats, the PLC follows a thermal map to increase the cooling flow rate at a pre-determined rate.

Even if the process conditions change rapidly or the machine is suddenly stopped, the cooling water flow rate is not allowed to change at more than safe rate.

Cooling Water Control is fully automatic requiring no Operator intervention. Electrical Interlocks require that the Operator starts the Cooling Water Pump before the Conform Machine can be started – during operation Wheel Cooling "looks after itself".

With such a system, Temperature Measurement is critical because thermocouple failure could result in under or over cooling with disastrous results.

BWE uses two thermocouples to measure Wheel Temperature and an arbitration algorithm in the PLC that rejects erroneous or unbelievable readings. In the unlikely event that both thermocouples fail, an alarm alerts the operator.

Features

- **Achieves Optimum Operating Temperature Rapidly.**
- **Maintains Optimum Operating Temperature Under Varying Conditions.**
- **Fully Automatic – No Operator Intervention Required.**
- **Reduces Thermal Stress.**
- **Extends Wheel Life.**